

Toggle Valves

STV Series

Features

- Compact design
- Quick acting
- Orifice sizes from 0.080 to 0.250 in. (2.0 to 6.4 mm)
- Flow coefficients (Cv) from 0.11 to 0.70
- Straight, angle flow patterns
- **SUPERLOK** tube fitting, male and female NPT and a variety of end connections available
- Every valve is factory tested

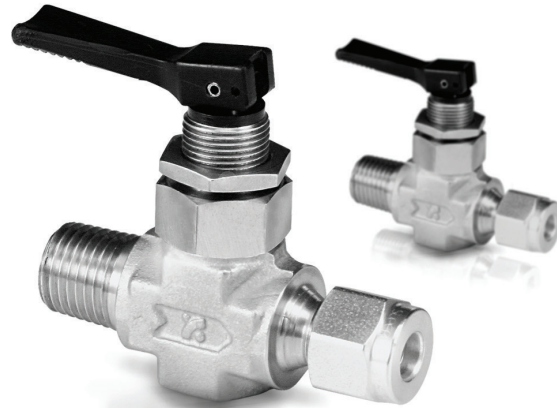

Technical Data

Series	Orifice in.(mm)	Pressure - Temperature Rating	
		Temperature °F(°C)	Working Pressure psig (bar)
STV1	0.080(2.0)	-20 to 200°F (-28 to 93°C)	300psig(20.6bar)
STV2	0.125(3.2)		200psig(13.7bar)
STV3	0.250(6.4)		

Materials of Construction

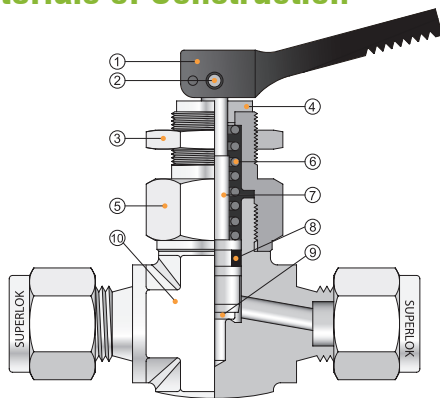

No.	Component	Material
1	Handle	Nylon
2	Roll Pin	Stainless Steel 304
3	Lock Nut	A276-316
4	Handle Washer	Nylon
5	Packing Nut	A276-316
6	Spring	Stainless Steel
7	Stem	A276-316
8	O-Ring	Viton
9	Stem Tip	PTFE
10	Body	A182-F316

Ordering Information

Example :

STV2 - M 4N - N - B

1
2
3
4
5

1. Valve Type

Straight Type

- STV1 : Orifice 2mm
- STV2 : Orifice 3.2mm
- STV3 : Orifice 6.4mm

Angle Type

- STV1A : Orifice 2mm
- STV2A : Orifice 3.2mm
- STV3A : Orifice 6.4mm

2. Port Type

- S : SUPERLOK Tube Fitting
- M : Male Pipe Thread
- F : Female Pipe Thread

4. O-Ring Material

- Blank : Viton
- N : NBR
- K : Kalez

3. Port Size

Pipe Thread Designation

Size (inch)	1/8	1/4
ISO Tapered	2R	4R
NPT	2N	4N

Tube O.D Designation

Tube O.D (inch)	1/8	1/4	3/8	1/2
Designation	2	4	6	8
Tube O.D (mm)	3	6	10	12
Designation	3M	6M	10M	12M

5. Body Material

- Blank : 316 Stainless Steel
- B : Brass

STRAIGHT TYPE

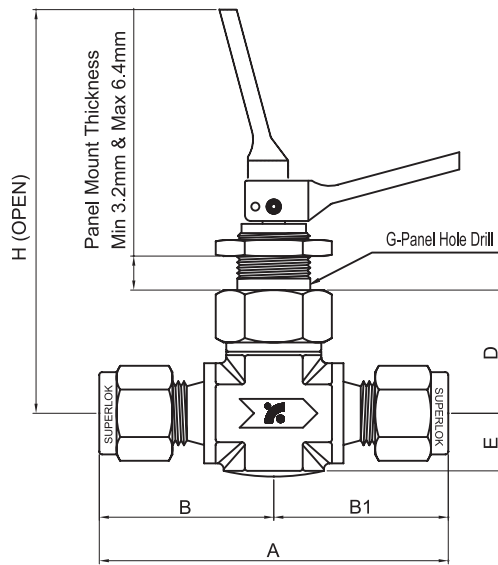

ANGLE TYPE

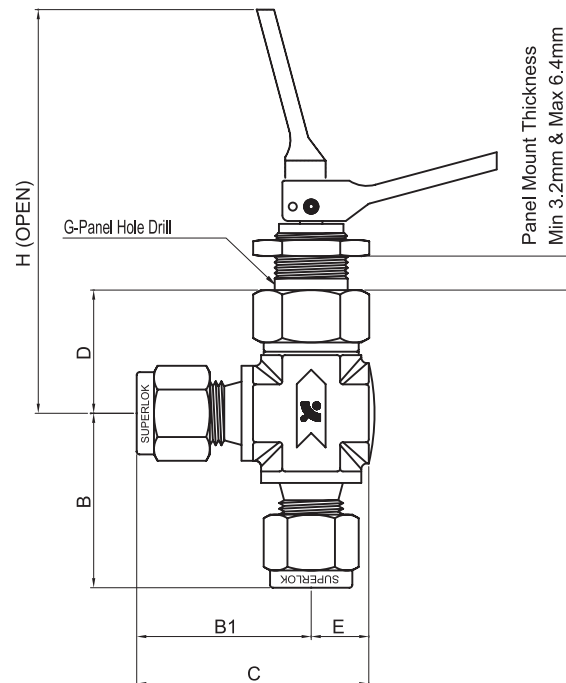

Table of Dimensions

Part Number	Orifice	Cv	End Connections		Dimensions								
			Inlet	Outlet	A	B	B1	C	D	E	G	H	
STV1	M2N	2.0	0.11	1/8" Male NPT		38.1	19.0	19.0	27.0	23.4	7.9	13.5	72.9
	M2N-S2			1/8" Male NPT	1/8" Superlok	43.9	19.0	24.9	32.8				
	S2			1/8" Superlok		49.8	24.9	24.9	32.8				
	S3M			3mm Superlok		49.8	24.9	24.9	32.8				
STV2	F2N	3.2	0.2	1/8" Female NPT		41.4	20.6	20.6	30.2	21.8	9.5	13.5	71.4
	M2N			1/8" Male NPT		43.7	21.8	21.8	31.2				
	M4N			1/4" Male NPT		49.8	24.9	24.9	34.5				
	M4N-S4			1/4" Male NPT	1/4" Superlok	53.6	24.9	28.7	38.1				
	M2N-F2N			1/8" Male NPT	1/8" Female NPT	41.4	20.6	20.6	30.2				
	S4			1/4" Superlok		57.4	28.7	28.7	38.1				
	S6M			6mm Superlok		57.4	28.7	28.7	38.1				
	S8M			8mm Superlok		56.4	28.2	28.2	37.6				
STV3	F4N	6.4	0.7	1/4" Female NPT		53.8	26.9	26.9	39.6	26.9	12.7	16.8	90.4
	M6N			3/8" Male NPT		57.2	28.4	28.4	41.1				
	S6			3/8" Superlok		65.5	32.8	32.8	45.5				
	S8			1/2" Superlok		71.7	35.6	35.6	48.9				
	S10M			10mm Superlok		69.1	34.5	34.5	47.2				
	S12M			12mm Superlok		74.2	37.1	37.1	49.8				

- All dimensions in millimeters unless specified as "inch". Dimension are for reference only, subject to change.
- Dimensions shown with SUPERLOK ends are measured with nuts in the finger tight position.
- ISO Tapered Threads are available upon request.